

Client: Mid Ocean Brands B.V.

Address: 7/F, Kings Tower, 111 King Lam Street, Cheung Sha Wan, Kowloon, Hong Kong.

The following merchandise was (were) submitted and identified by the client as:

Name of Product: Multifunctional COB Light

Item No.: MO6702

Sample Received: Dec. 25, 2023
Jan. 05, 2024
Jan. 23, 2024

Test Period: Dec. 25, 2023 - Jan. 25, 2024

This report replaces the original report which is numbered JTS23121260-1ER5.

Overall Result : PASS

Test specification : Please refer to next page.

Prepared by : Summer
Testing Engineer

Reviewed By : Ava
Quality Manager

Issued By : Carl
Authorized Signatory



NPS Survey



Verification Report

Test Requested and Conclusion(s):

No.	Test Sample	Standard and Requirement	Conclusion(s)
1	Submitted sample	As requested by the client, According to RoHS Directive 2011/65/EU(RoHS 2.0) and its subsequent amendments Directive (EU) 2015/863. Split the sample and determine the Pb, Cd, Hg, Cr (VI),PBBs, PBDEs, DEHP, BBP, DBP&DIBP content of the parts.	PASS
2	Submitted sample	Total Lead,Cadmium and Mercury content according to Annex I of Regulation (EU)2023/1542	PASS

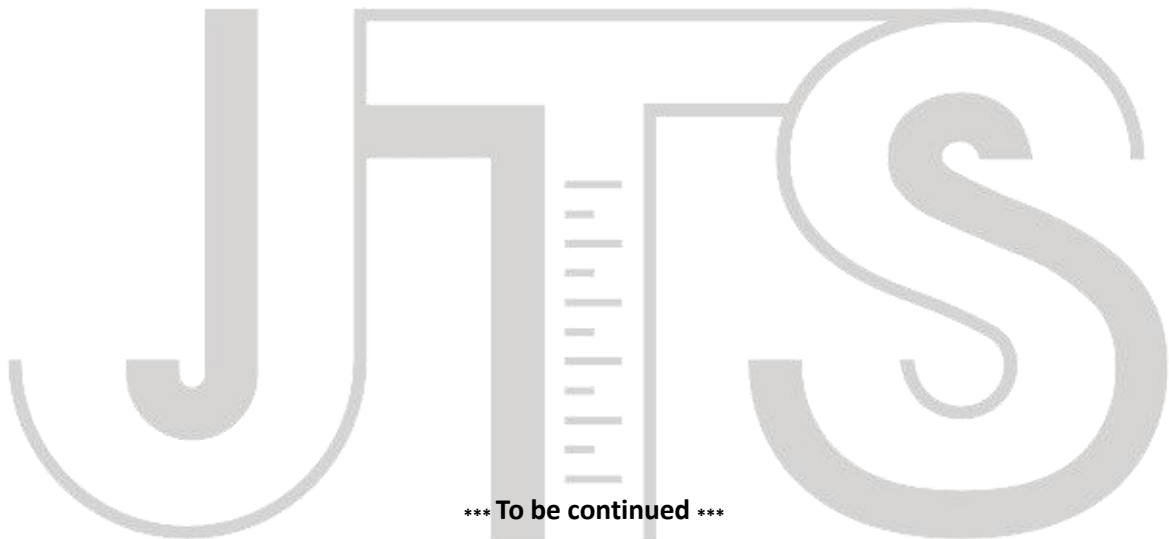

*** To be continued ***

Test Result(s):

1.Pb, Cd, Hg, Cr (VI),PBBs, PBDEs, DEHP, BBP, DBP&DIBP content of the parts.

Test Methods:

1. Sample prepared with reference to IEC 62321-2:2021 Determination of certain substances in electro technical products - Part 2: Disassembly, disjunction and mechanical sample preparation
2. Sample Screening testing with reference to IEC 62321-3-1:2013 Determination of certain substances in electrotechnical products - Part 3-1: Screening - Lead, mercury, cadmium, total chromium and total bromine using X-ray fluorescence spectrometry.
3. Wet Chemical Test Method
 - a. Determination of Lead ,Cadmium by ICP-OES with reference to IEC 62321-5:2013
 - b. Determination of Mercury by ICP-OES with reference to IEC 62321-4:2013+A1:2017
 - c. Determination of Hexavalent Chromium by UV-Vis Method with reference to IEC 62321-7-1:2015 or IEC 62321-7-2:2017
 - d. Determination of PBBs and PBDEs by GC-MS with reference to IEC 62321-6:2015
 - e. Determination of Phthalates by GC-MS with reference to IEC 62321-8:2017

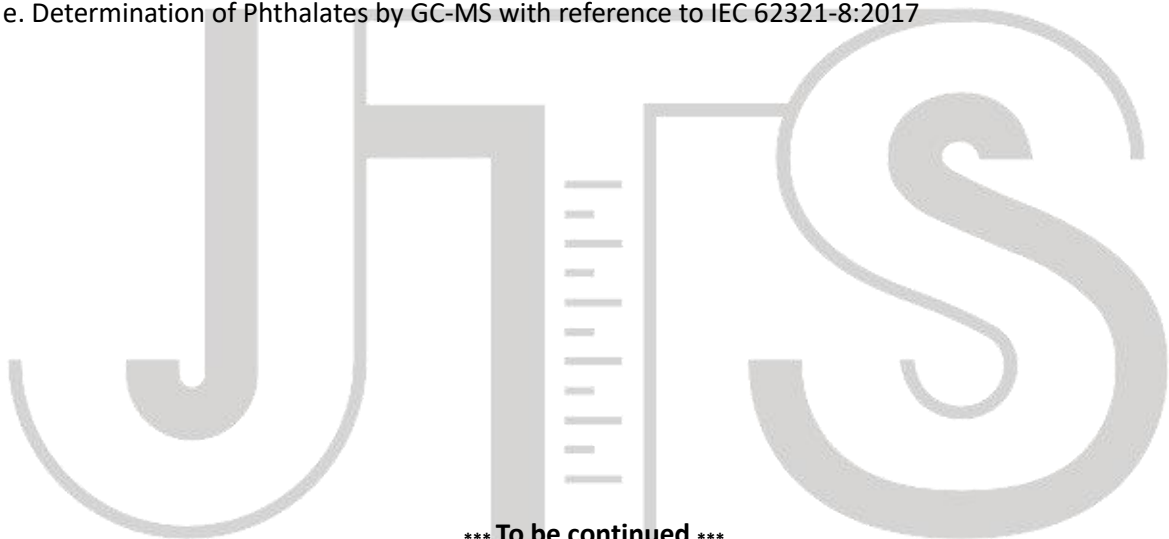

*** To be continued ***

TEST REPORT

Report No.: JTS23121260-1ER6

Date: Jan. 26, 2024

Page 4 of 15

Part No.	Test Part Description	Note	Test Results ⁽¹⁾⁽²⁾ (mg/kg)									
			Pb	Cd	Hg	Cr(VI)	PBBs	PBDEs	DEHP	BBP	DBP	DIBP
1	Transparent plastic lampshade	XRF	BL	BL	BL	BL	BL		---	---	---	---
		CHEM	---	---	---	---	---	---	N.D.	N.D.	N.D.	N.D.
2	Black plating metal shell	XRF	BL	BL	BL	IN	---		---	---	---	---
		CHEM	---	---	---	Neg.	---	---	---	---	---	---
3	Black rubber sheath	XRF	BL	BL	BL	BL	BL		---	---	---	---
		CHEM	---	---	---	---	---	---	N.D.	N.D.	N.D.	N.D.
4	Black plastic frame	XRF	BL	BL	BL	BL	BL		---	---	---	---
		CHEM	---	---	---	---	---	---	N.D.	N.D.	N.D.	N.D.
5	Yellow rubber LED	XRF	BL	BL	BL	BL	BL		---	---	---	---
		CHEM	---	---	---	---	---	---	N.D.	N.D.	N.D.	N.D.
6	Silvery metal solder tin	XRF	IN	BL	BL	BL	---		---	---	---	---
		CHEM ^R	35	---	---	---	---	---	---	---	---	---
7	Red wire jacket	XRF	BL	BL	BL	BL	BL		---	---	---	---
		CHEM	---	---	---	---	---	---	N.D.	N.D.	N.D.	N.D.
8	Green PCB	XRF	BL	BL	BL	BL	BL		---	---	---	---
		CHEM	---	---	---	---	---	---	N.D.	N.D.	N.D.	N.D.
9	Silvery metal solder tin	XRF	BL	BL	BL	BL	---		---	---	---	---
		CHEM	---	---	---	---	---	---	---	---	---	---
10	Yellow transparent plastic tape	XRF	BL	BL	BL	BL	BL		---	---	---	---
		CHEM	---	---	---	---	---	---	N.D.	N.D.	N.D.	N.D.
11	Blue wire jacket	XRF	BL	BL	BL	BL	BL		---	---	---	---
		CHEM	---	---	---	---	---	---	N.D.	N.D.	N.D.	N.D.
12	Silvery metal solder tin	XRF	BL	BL	BL	BL	---		---	---	---	---
		CHEM	---	---	---	---	---	---	---	---	---	---
13	Black plastic sheath	XRF	BL	BL	BL	BL	BL		---	---	---	---
		CHEM	---	---	---	---	---	---	N.D.	N.D.	N.D.	N.D.

*** To be continued ***

TEST REPORT

Report No.: JTS23121260-1ER6

Date: Jan. 26, 2024

Page 5 of 15

Part No.	Test Part Description	Note	Test Results ⁽¹⁾⁽²⁾ (mg/kg)									
			Pb	Cd	Hg	Cr(VI)	PBBs	PBDEs	DEHP	BBP	DBP	DIBP
14	Silvery metal shell	XRF	BL	BL	BL	BL		---	---	---	---	---
		CHEM	---	---	---	---	---	---	---	---	---	---
15	Silvery metal solder tin	XRF	BL	BL	BL	BL		---	---	---	---	---
		CHEM	---	---	---	---	---	---	---	---	---	---
16	White plastic frame	XRF	BL	BL	BL	BL		BL	---	---	---	---
		CHEM	---	---	---	---	---	---	N.D.	N.D.	N.D.	N.D.
17	Silvery metal pin	XRF	BL	BL	BL	BL		---	---	---	---	---
		CHEM	---	---	---	---	---	---	---	---	---	---
18	Silvery metal shell	XRF	BL	BL	BL	IN		---	---	---	---	---
		CHEM	---	---	---	Neg.	---	---	---	---	---	---
19	Black plastic sheath	XRF	BL	BL	BL	BL		BL	---	---	---	---
		CHEM	---	---	---	---	---	---	N.D.	N.D.	N.D.	N.D.
20	Silvery metal solder tin	XRF	BL	BL	BL	BL		---	---	---	---	---
		CHEM	---	---	---	---	---	---	---	---	---	---
21	Black plastic frame	XRF	BL	BL	BL	BL		BL	---	---	---	---
		CHEM	---	---	---	---	---	---	N.D.	N.D.	N.D.	N.D.
22	Black chip resistor	XRF	IN	BL	BL	BL		BL	---	---	---	---
		CHEM	708	---	---	---	---	---	N.D.	N.D.	N.D.	N.D.
23	Red PCB	XRF	BL	BL	BL	BL		IN	---	---	---	---
		CHEM	---	---	---	---	N.D.	N.D.	N.D.	N.D.	N.D.	N.D.
24	Golden metal pin	XRF	BL	BL	BL	BL		---	---	---	---	---
		CHEM	---	---	---	---	---	---	---	---	---	---
25	Silvery metal pin	XRF	BL	BL	BL	IN		---	---	---	---	---
		CHEM	---	---	---	Neg.	---	---	---	---	---	---
26	Black insulation jacket	XRF	BL	BL	BL	BL		BL	---	---	---	---
		CHEM	---	---	---	---	---	---	N.D.	N.D.	N.D.	N.D.

*** To be continued ***

TEST REPORT

Report No.: JTS23121260-1ER6

Date: Jan. 26, 2024

Page 6 of 15

Part No.	Test Part Description	Note	Test Results ⁽¹⁾⁽²⁾ (mg/kg)									
			Pb	Cd	Hg	Cr(VI)	PBBs	PBDEs	DEHP	BBP	DBP	DIBP
27	Red wire jacket	XRF	BL	BL	BL	BL	BL		---	---	---	---
		CHEM	---	---	---	---	---	---	N.D.	N.D.	N.D.	N.D.
28	Black wire jacket	XRF	BL	BL	BL	BL	BL		---	---	---	---
		CHEM	---	---	---	---	---	---	N.D.	N.D.	N.D.	N.D.
29	Coppery metal wire	XRF	BL	BL	BL	BL	---		---	---	---	---
		CHEM	---	---	---	---	---	---	---	---	---	---
30	Silvery magnet sheet	XRF	BL	BL	BL	BL	---		---	---	---	---
		CHEM	---	---	---	---	---	---	---	---	---	---
31	Silvery metal part	XRF	BL	BL	BL	BL	---		---	---	---	---
		CHEM	---	---	---	---	---	---	---	---	---	---
32	Black plating metal screw	XRF	BL	BL	BL	IN	---		---	---	---	---
		CHEM	---	---	---	Neg.	---	---	---	---	---	---
33	Black chip resistor (1K)	XRF	IN	BL	BL	BL	BL		---	---	---	---
		CHEM	574	---	---	---	---	---	N.D.	N.D.	N.D.	N.D.
34	Black chip resistor (100R)	XRF	IN	BL	BL	BL	BL		---	---	---	---
		CHEM	659	---	---	---	---	---	N.D.	N.D.	N.D.	N.D.
35	White chip LED (Red)	XRF	BL	BL	BL	BL	BL		---	---	---	---
		CHEM	---	---	---	---	---	---	N.D.	N.D.	N.D.	N.D.
36	White chip LED (Green)	XRF	BL	BL	BL	BL	BL		---	---	---	---
		CHEM	---	---	---	---	---	---	N.D.	N.D.	N.D.	N.D.
37	Black IC	XRF	BL	BL	BL	BL	BL		---	---	---	---
		CHEM	---	---	---	---	---	---	N.D.	N.D.	N.D.	N.D.
38	Black IC	XRF	BL	BL	BL	BL	BL		---	---	---	---
		CHEM	---	---	---	---	---	---	N.D.	N.D.	N.D.	N.D.
39	Black plastic button	XRF	BL	BL	BL	BL	BL		---	---	---	---
		CHEM	---	---	---	---	---	---	N.D.	N.D.	N.D.	N.D.

*** To be continued ***

TEST REPORT

Report No.: JTS23121260-1ER6

Date: Jan. 26, 2024

Page 7 of 15

Part No.	Test Part Description	Note	Test Results ⁽¹⁾⁽²⁾ (mg/kg)									
			Pb	Cd	Hg	Cr(VI)	PBBs	PBDEs	DEHP	BBP	DBP	DIBP
40	Silvery metal frame	XRF	BL	BL	BL	BL	---		---	---	---	---
		CHEM	---	---	---	---	---	---	---	---	---	---
41	Silvery metal sheet	XRF	BL	BL	BL	IN	---		---	---	---	---
		CHEM	---	---	---	Neg.	---	---	---	---	---	---
42	Silvery metal pin	XRF	BL	BL	BL	BL	---		---	---	---	---
		CHEM	---	---	---	---	---	---	---	---	---	---
43	Beige plastic frame	XRF	BL	BL	BL	BL	BL		---	---	---	---
		CHEM	---	---	---	---	---	---	N.D.	N.D.	N.D.	N.D.
44	Silvery metal shell	XRF	BL	BL	BL	IN	---		---	---	---	---
		CHEM	---	---	---	Neg.	---	---	---	---	---	---
45	Black plastic frame	XRF	BL	BL	BL	BL	BL		---	---	---	---
		CHEM	---	---	---	---	---	---	N.D.	N.D.	N.D.	N.D.
46	Coppery metal pin	XRF	BL	BL	BL	BL	---		---	---	---	---
		CHEM	---	---	---	---	---	---	---	---	---	---
47	Silvery metal rivet	XRF	BL	BL	BL	BL	---		---	---	---	---
		CHEM	---	---	---	---	---	---	---	---	---	---

"R" The arrival date of the sample is Jan. 05, 2024

*** To be continued ***

(1) For results of XRF

(a) It is the result on total Br while test item on restricted substances is PBBs/PBDEs. It is the result on total Cr while test item on restricted substances is Cr⁶⁺.

(b) Results are obtained by EDXRF for primary screening, and further chemical testing by ICP-OES (for Cd, Pb, Hg), UV-Vis (for Cr⁶⁺) and GC/MS (for PBBs, PBDEs) is recommended to be performed, if the concentration exceeds the below warning value according to IEC 62321-3-1:2013 (unit: mg/kg)

Element	Polymer	Metal	Composite Materials
Cd	$BL \leq (70-3\sigma) < X < (130+3\sigma) \leq OL$	$BL \leq (70-3\sigma) < X < (130+3\sigma) \leq OL$	$LOD < X < (150+3\sigma) \leq OL$
Pb	$BL \leq (700-3\sigma) < X < (1300+3\sigma) \leq OL$	$BL \leq (700-3\sigma) < X < (1300+3\sigma) \leq OL$	$BL \leq (500-3\sigma) < X < (1500+3\sigma) \leq OL$
Hg	$BL \leq (700-3\sigma) < X < (1300+3\sigma) \leq OL$	$BL \leq (700-3\sigma) < X < (1300+3\sigma) \leq OL$	$BL \leq (500-3\sigma) < X < (1500+3\sigma) \leq OL$
Br	$BL \leq (300-3\sigma) < X$	--	$BL \leq (250-3\sigma) < X$
Cr	$BL \leq (700-3\sigma) < X$	$BL \leq (700-3\sigma) < X$	$BL \leq (500-3\sigma) < X$

(c) BL = Below Limit, OL = Over Limit, IN = Inconclusive, LOD = Limit of Detection, -- = Not Regulated, NA = Not Applicable.

(d) The XRF screening test for RoHS elements – The reading may be different to the actual content in the sample be of non-uniformity composition.

(2) For results of Chemical testing

(a) mg/kg = ppm = 0.0001%, N.D.= Not Detected (<MDL), --- = Not Conducted.

(b) Unit and Method Detection Limit (MDL) in wet chemical test

Test Items	Pb	Cd	Hg	DEHP	BBP	DBP	DIBP
Units	mg/kg	mg/kg	mg/kg	mg/kg	mg/kg	mg/kg	mg/kg
MDL	10	10	10	500	500	500	500

The MDL for single compound of PBBs & PBDEs is 10 mg/kg and MDL of Cr⁶⁺ for polymer & composite sample is 10 mg/kg.

(c) According to IEC 62321-7-1:2015, result on Cr⁶⁺ for metal sample is shown as Pos./Neg.

Pos. =Positive, Neg. = Negative

Pos. = Presence of Cr⁶⁺ coating, Neg. = Absence of Cr⁶⁺ coating.

*** To be continued ***

(3)RoHS Requirement

Restricted substances	Limits
Lead (Pb)	0.1% (1000mg/kg)
Cadmium (Cd)	0.01% (100mg/kg)
Mercury (Hg)	0.1% (1000mg/kg)
Chromium (VI) (Cr ⁶⁺)	0.1% (1000mg/kg)
Polybrominated biphenyls (PBBs)	0.1% (1000mg/kg)
Polybrominated diphenyl ethers (PBDEs)	0.1% (1000mg/kg)
Di-(2-ethylhexyl) phthalate (DEHP)	0.1% (1000mg/kg)
Benzyl butyl phthalate (BBP)	0.1% (1000mg/kg)
Di-n-butyl phthalate (DBP)	0.1% (1000mg/kg)
Di-isobutyl phthalate (DIBP)	0.1% (1000mg/kg)

2. Lead, Cadmium and Mercury content

Method: For Pb and Cd content: With reference to IEC62321-5:2013, Analysis was performed by ICP-MS.
For Hg content: With reference to IEC 62321-4:2013+A1:2017, Analysis was performed by ICP-MS.

Test Item(s)	MDL (mg/kg)	Test Results(mg/kg)	Labelling Requirement (mg/kg)	HLV (mg/kg)
		48		
Pb	2	N.D.	>40	100
Cd	2	N.D.	>20	20
Hg	2	N.D.	--	5

Material No.	Description	Location
48	Silver battery	Battery

- Note:**
- 1)MDL = Method Detection Limit
 - 2)N.D.= Not detected, less than MDL.
 - 3)All batteries containing more than 0.002 %cadmium or more than 0.004 %lead,shall be1)marked with the chemical symbol for the metal concerned:Cd or Pb.The relevantchemical symbol indicating the heavy metal content shall be printed beneath the separatecollection symbol as shown in Part B of Annex VI in Regulation (EU)2023/1542 and shallcover an area of at least one-quarter the size of that symbol;
 - 4)---=Not Regulated;
 - 5) The limited value is based on Annex I of Regulation (EU)2023/1542;
 - 6)The limited value shall apply to portable batteries,whether or not incorporated intoappliances from 18 August 2024 and not apply to portable zinc-air button cells until18 August 2028.
 - 7)HLV = Hazardous limited value.

*** To be continued ***

Sample Photos

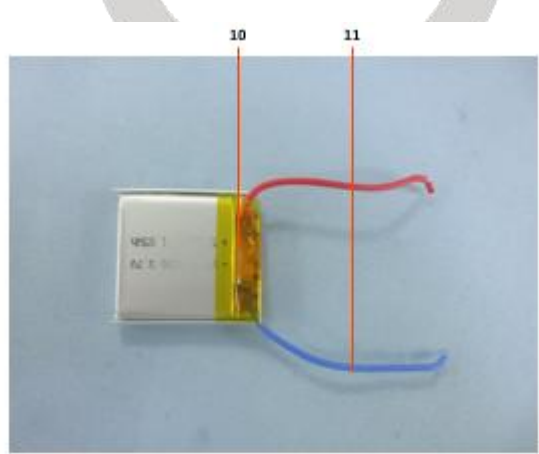
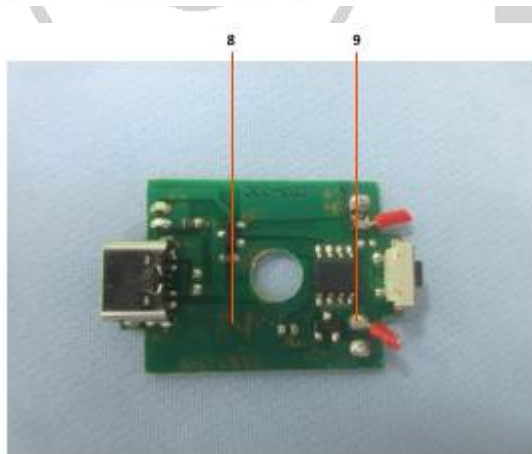
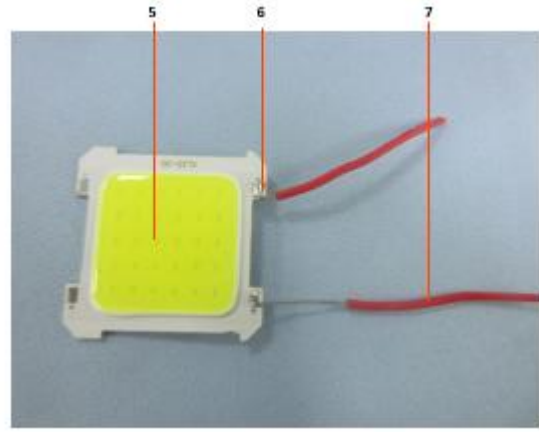
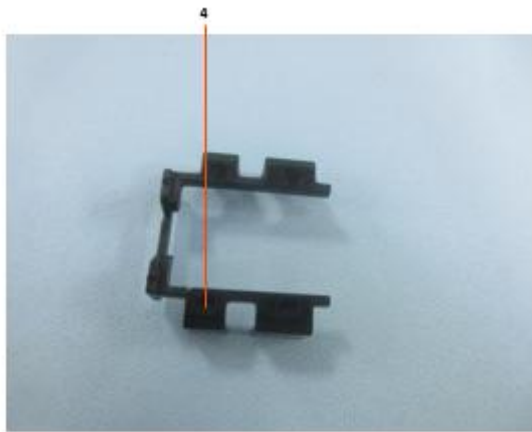

*** To be continued ***

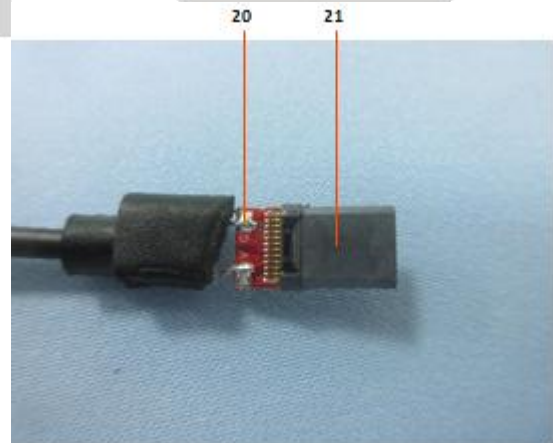
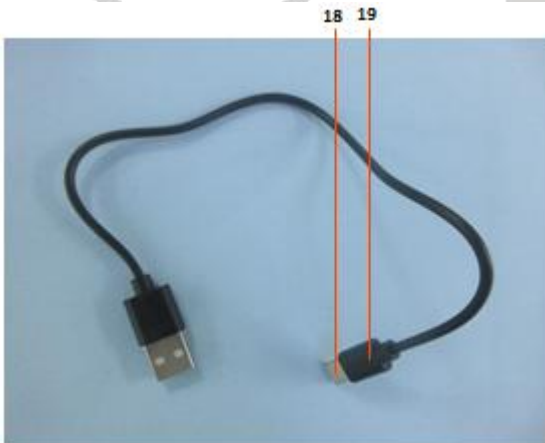
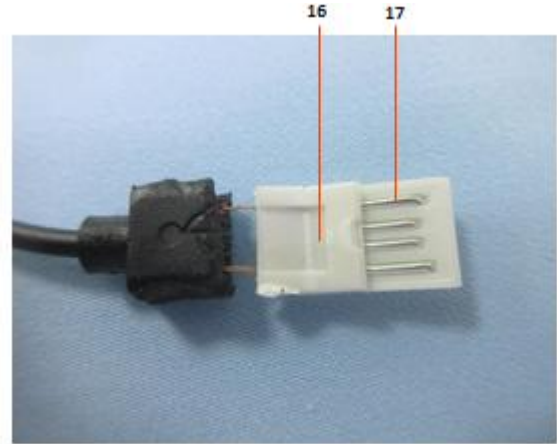
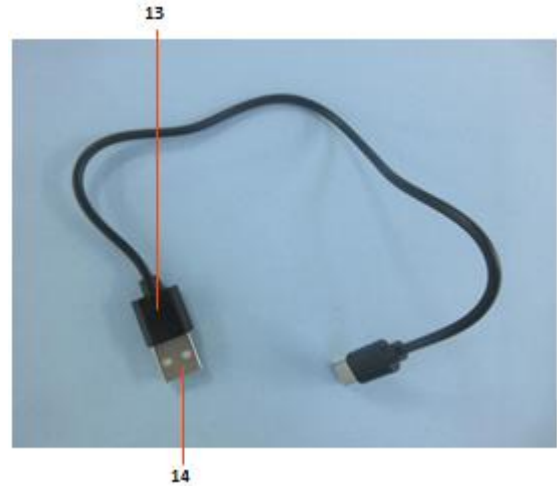
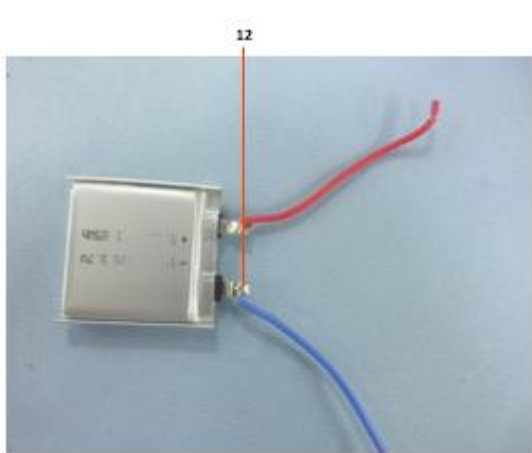

*** To be continued ***

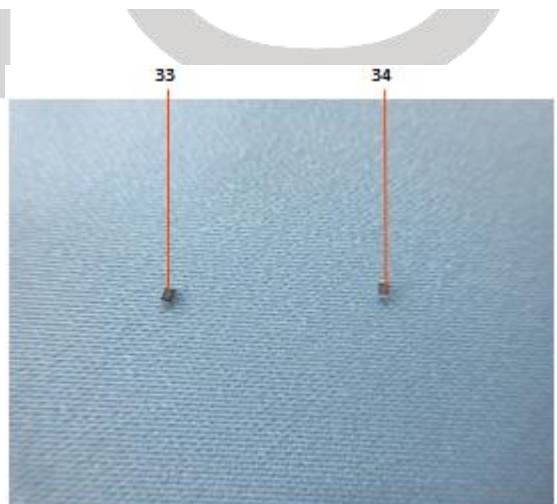
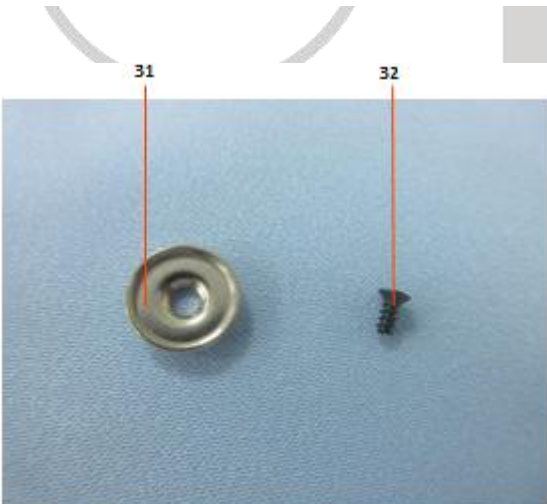
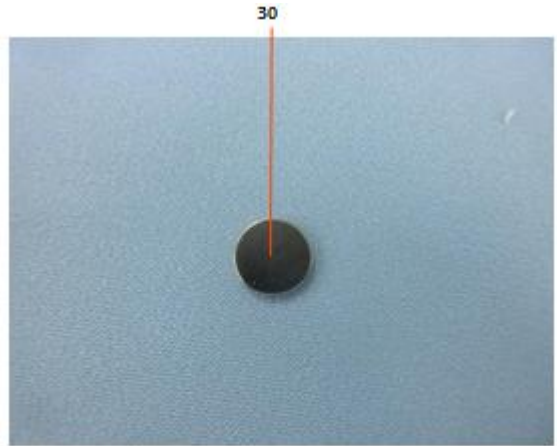
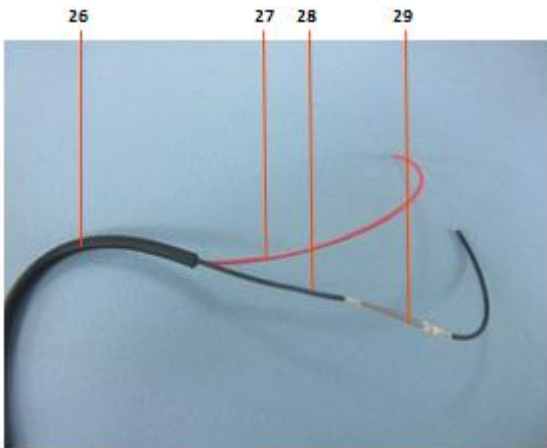
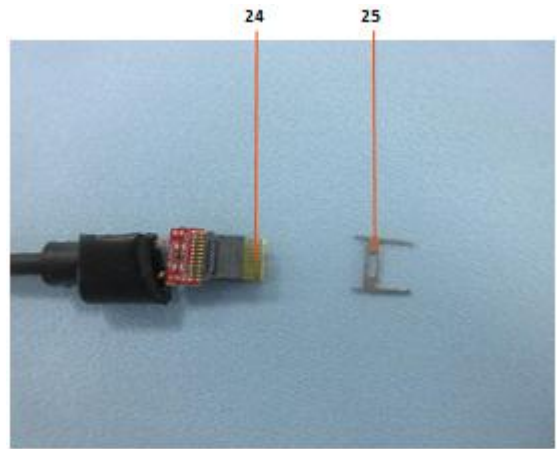
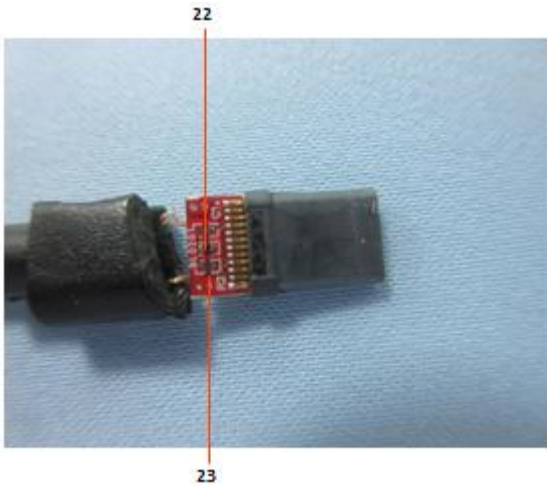

*** To be continued ***

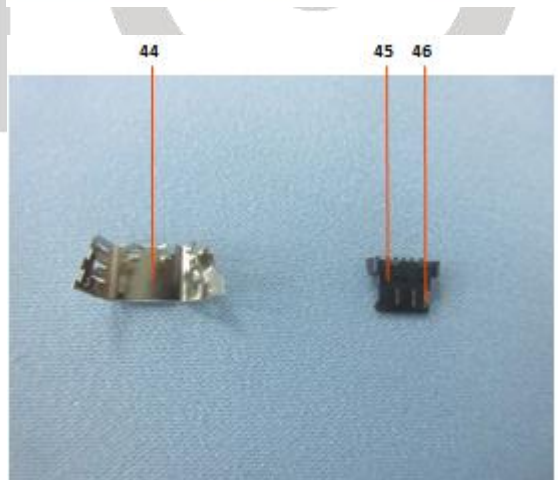
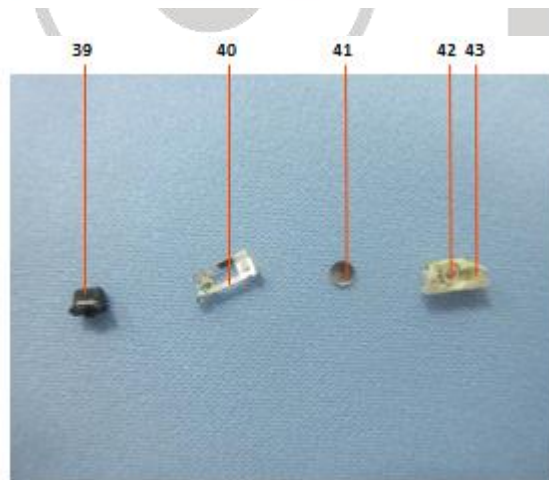
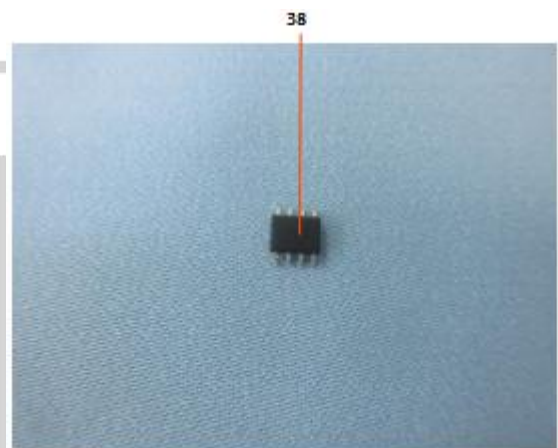
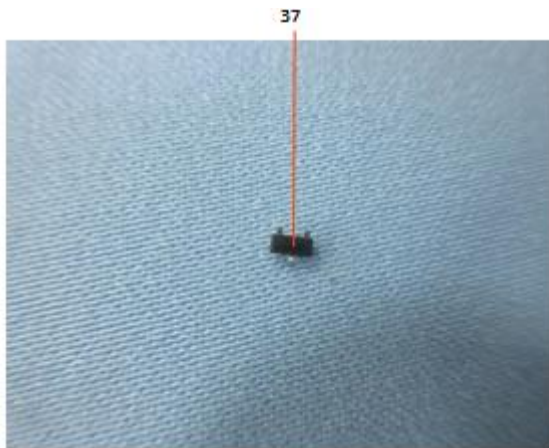
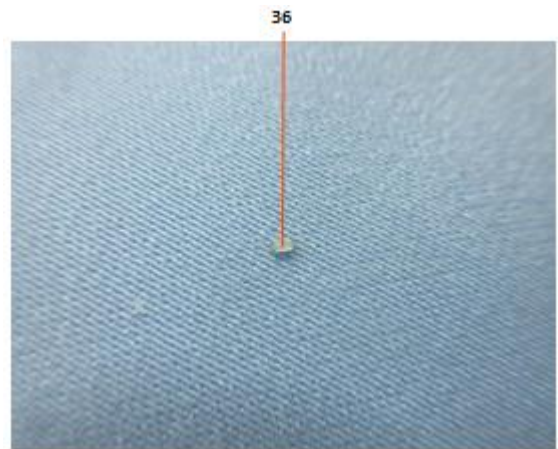
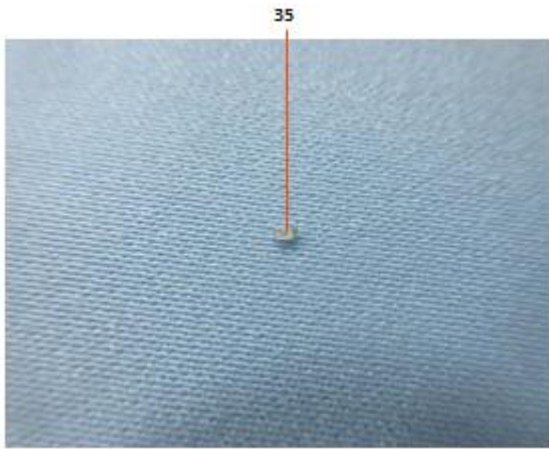

*** To be continued ***



Product Photos



23121260

*** End of Report ***



TEST REPORT

Report No.: JTS23121260-1ER6

Date: Jan. 26, 2024

Page 15 of 15

GENERAL CONDITIONS OF SERVICES

JTS Testing Services Co.,Ltd. (hereinafter "JTS"), while reserving the right to decline, without giving any reason whatsoever, any request for the undertaking of a test or investigation, will carry out at the request of the clients the required test or investigation subject always to the following conditions:

1. JTS only acts for the person or body originating the instructions (the "Clients"). No other party is entitled to give instructions, particularly on the scope of testing or delivery of report or certificate, unless authorized by the Clients.
2. The Sample(s) to be tested or investigated shall be delivered at the costs of the Clients and in accordance with the requirements of JTS. Improper shipping, packaging, and labeling of the Sample(s) by the Client may result in incorrect testing results, JTS shall be under no obligation to the Clients. At the conclusion of the test or investigation, the Clients shall, if required by JTS, collect the Sample(s). In any event, if the Sample(s) are not collected by the Clients within 30 days from the issuance date of the test report (for perishable items such as food and water samples, the relevant period shall be the preserving period up to 15 days), JTS may at its discretion dispose of the Sample(s) without any compensation to the Clients.
3. The Clients shall always comply with the following before or during JTS providing its services:
 - a) provide sample(s) and relevant data, at the same time, guarantee the consistence of the sample(s) name they declared with the sample(s) or the goods provided. Otherwise, JTS will not bear any relevant responsibilities;
 - b) giving timely instructions and adequate information to enable JTS to perform the services effectively;
 - c) supply, when requested by JTS, any equipment and personnel for the performance of the services;
 - d) take all necessary steps to eliminate or remedy any obstruction in the performance of the services;
 - e) inform JTS in advance of any hazards or dangers, actual or potential, associated with any order of samples or testing;
 - f) provide all necessary access for JTS's representative to enable the required services to be performed effectively;
 - g) ensure all essential steps are taken for safety of working conditions, sites and installations during the performance of services;
 - h) fully discharge all its liabilities under any contract like sales contract with a third party, whether or not a report or certificate has been issued by JTS, failing which JTS shall be under no obligation to the Clients.
4. Subject to JTS's accepting the Client's instructions, JTS will issue reports or certificates which reflect statements of opinion made with due care within the scope of instructions but JTS is not obliged to report upon any facts outside the instructions, if there were any dissidence about the report or certificate, the Client should provide the written declaration to JTS within 15 days after the date receiving the report or certificate, otherwise, JTS will not hear the case after the date limit.
5. JTS is irrevocably authorized by the Clients to deliver at its discretion the report or the certificate to any third party when instructed by the Clients or where it implicitly follows from circumstances, trade custom, usage or practice as determined by JTS.
6. A test report will be issued in confidence to the Clients and it will be strictly treated as such by JTS. It may not be reproduced either in its entirety or in part and it may not be used for advertising or other unauthorized purposes without the written consent of JTS. The Clients to whom the Report is issued may, however, show or send it, or a certified copy thereof prepared by JTS, to his customer, supplier or other persons directly concerned. JTS will not, without the consent of the Clients, enter into any discussion or correspondence with any third party concerning the contents of the report unless required by the relevant governmental authorities, laws or court orders.
7. Applicants wishing to use JTS's reports in court proceedings or arbitration shall inform JTS to that effect prior to submitting the sample for testing.
8. The report will refer only to the sample tested and will not apply to the bulk, unless the sampling has been carried out by JTS and is stated as such in the Report. Also, the report is only for reference.
9. Any documents containing engagements between the Clients and third parties like contracts of sale, letters of credit, bills of lading, etc. are regarded as information for JTS only and do not affect the scope of the services or the obligations accepted by JTS.
10. If the Clients do not specify the methods/standards to be applied, JTS will choose the appropriate ones and further information regarding the methods can be obtained by direct contact with JTS, for the in-house method, JTS will only provide the summary.
11. No liability shall be incurred by and no claim shall be made against JTS or its servants, agents, employees or independent contractors in respect of any loss or damage to any such materials, equipment and property occurring whilst at JTS or any work places in which the testing is carried out, or in the course of transit to or from JTS or the said work places, whether or not resulting from any acts, neglect or default on the part of any such servants, agents, employees or independent contractors of JTS.
12. JTS will not be liable, or accept responsibility for any loss or damage howsoever arising from the use of information contained in any of its reports or in any communication whatsoever about its said tests or investigations.
13. Subject to Clause 11 and 12, the total liability of JTS in respect of any claim of loss, damage or expense of whatsoever nature shall not exceed a total sum equal to two times the amount of the service fee payable in respect of the services directly related to such claim, and JTS's liability shall not include any indirect, special or consequential loss of the Clients.
14. In the event of JTS prevented by any cause outside JTS's control from performing any service for which an order has been given or an agreement made, the Clients shall pay to JTS:
 - a) the amount of all abortive expenditure actually made or incurred;
 - b) a proportion of the agreed fee or commission equal to the proportion (if any) of the service actually carried out by JTS, and JTS shall be relieved of all responsibility whatsoever for the partial or total non-performance of the required service.
15. JTS shall be discharged from all liabilities for all claims for loss, damage or expense unless suit is brought within one calendar year after the date of the performance by JTS of the service relating to the claim or in the event of any alleged non-performance within one year of the date when such service should have been completed.
16. The Clients acknowledge that JTS does not, either by entering into a contract or by performing service, assume or undertake to discharge any duty of the Clients to any other persons. JTS is neither an insurer nor a guarantor and disclaims all liability in such capacity.
17. The Clients shall hold harmless and indemnify JTS and its officers, employees, agents or independent contractors against all claims made by any third party for loss, damage or expense of whatsoever nature including reasonable legal expenses relating to the performance or non-performance of any services to the extent that the aggregate of any such claims relating to any one service exceed the limits mentioned in Clause 13.
18. Any unauthorized alteration, forgery or falsification of the content or appearance of the report/certificate is unlawful and offenders may be prosecuted to the fullest extent of the law; in the event of improper use of the report, JTS reserves the right to withdraw it, and to adopt any other measures which may be appropriate.
19. Samples are deposited with and accepted by JTS on the basis that either they are insured by the Clients or the Clients assumes entire responsibility for loss through fire, theft, burglary or for damages arising in the course of analysis or handling, without recourse whatsoever to JTS or its servants, agent, employees or independent contractors.
20. If the requirements of the Clients require the analysis of samples by the Clients' or any third party's laboratory, JTS will only convey the result of the analysis without responsibility for its accuracy. If JTS is only able to witness an analysis by the Clients' or any third Party's laboratory JTS will only confirm that the correct sample has been analyzed without responsibility for the accuracy of any analysis or results.
21. In the event of any unforeseen additional time or costs being incurred in the course of carrying out any of its services, JTS shall be entitled to charge the Clients additional fees to reflect the additional time and costs incurred.
22. All rights (including but not limited to copyright) in any reports, certificates or other materials produced by JTS in the course of providing its services shall remain vested in JTS.
23. Unless otherwise agreed in writing, payment is to be made within 10 days from the date of Invoice or the date of the Debit Note, all charges rendered by JTS or interest will become due at the rate of three percent per month from the date of invoice until actual payment. The Clients are also responsible for settling all JTS's costs of collecting the charges owed, including legal fees.
24. Test results may be transmitted by electronic means at the Client's request. However, it should be noted that electronic transmission cannot guarantee the information contained will not be lost, delayed or intercepted by third party. JTS is not liable for any disclosure, error or omission in the content of such messages as a result of electronic transmission.
25. If necessary, JTS may subcontract part of or all tests to competent subcontractors. If no objection is raised at the time of the Clients submitting the application, JTS shall assume the Client's approval.
26. This report/certificate does not relieve sellers/suppliers from their contractual responsibility with regards to the quality/quantity of this delivery nor does it prejudice the Client's right to claim towards sellers/suppliers for compensation for any apparent and/or hidden defects not detected during JTS's random inspection or testing or audit.
27. JTS reserves the right to include Special Conditions in addition to the foregoing General Conditions if warranted by the particular circumstances of the required test or investigation [this clause is only effective when the other party has been informed.
28. The foregoing General Conditions shall in all respects be governed, construed, interpreted and operated in accordance with the relevant Chinese laws and regulations. Unless otherwise agreed, the arbitration shall take place in P. R. C.
29. These General Condition have been drafted in Chinese and may be translated into other languages. In the event of any discrepancy, the Chinese version shall prevail.
30. In general sample will be stored for 30 days. But for liquid, powder, etc semi-product & fragile product, it will be stored only for 15 days.
31. The data of RoHS Directive is derived from the contract report numbered 2023121146.

Zhejiang J-testing Service Co.,Ltd.

Add: West of 3rd Floor, No.5 No.968 Xuefeng West Road, Beiyuan Street, Yiwu, Zhejiang, China 322000
Customer service: info@j-testing.com/+86 057985309611 Web: www.jts-cert.com

IEC 62133-2 TEST REPORT

For
Li-ion Cell
Model: 582728

Prepared for:

Prepared by: Shenzhen NCT Testing Technology Co., Ltd.
B2A101/B2A201/B2A202, Fuqiao 6th Area, Xintian, Fuhai Subdistrict,
Bao'an District, Shenzhen, Guangdong, China
TEL: +86-755-23218380

Report Number: NCT24010136XI1-1
Date of Test: 2024-02-29 to 2023-03-13
Date of Issue: 2024-03-13

Tested By: Dylan Zhu
Dylan Zhu

Reviewed By: Miya Li
Miya Li

Approved By: Boris Lin
Boris Lin



The results detailed in this test report relate only to the specific sample(s) tested. This report is not to be reproduced except in full, without written approval from NCT Testing Technology.

TEST REPORT IEC 62133-2 Secondary cells and batteries containing alkaline or other non-acid electrolytes – Safety requirements for portable sealed secondary cells, and for batteries made from them, for use in portable applications- Part 2: Lithium systems	
Report Number:	NCT24010136XI1-1
Date of issue:	2024-03-13
Total number of pages:	23 pages
Applicant's name:	
Address:	
Test specification:	
Standard:	IEC 62133-2:2017+AMD1:2021
Test procedure:	Test Report
Non-standard test method:	N/A
Test item description:	Li-ion Cell
Trade Mark:	XY
Manufacturer:	
Address:	
Model/Type reference:	582728
Ratings:	3.7V, 400mAh, 1.48Wh

Testing procedure and testing location:	
Testing Laboratory:	
Testing location/ address..... : Shenzhen NCT Testing Technology Co., Ltd. B2A101/B2A201/B2A202, Fuqiao 6th Area, Xintian, Fuhai Subdistrict, Bao'an District, Shenzhen, Guangdong, China	
List of Attachments:	
Appendix 1: 1 page of Photo Documentation	
Summary of testing:	
Tests performed (name of test and test clause):	Testing location:
cl.7.1 Charging procedure for test purposes (for Cells); cl.7.2.1 Continuous charging at constant voltage (cells); cl.7.3.1 External short circuit (cells); cl.7.3.3 Free fall (cells); cl.7.3.4 Thermal abuse (cells); cl.7.3.5 Crush (cells); cl.7.3.7 Forced discharge (cells); cl.7.3.9 Design evaluation – Forced internal short circuit (cells)	Shenzhen NCT Testing Technology Co., Ltd. B2A101/B2A201/B2A202, Fuqiao 6th Area, Xintian, Fuhai Subdistrict, Bao'an District, Shenzhen, Guangdong, China
Tests are made with the number of cells and batteries specified in IEC 62133-2:2017+AMD1:2021 Table 1.	
Summary of compliance with National Differences	
N/A	
<input checked="" type="checkbox"/> The product fulfils the requirements of <u>EN 62133-2: 2017+A1:2021</u>	

Copy of marking plate

The artwork below may be only a draft. The use of certification marks on a product must be authorized by the respective NCBs that own these marks.

N/A

Information for safety mentioned on equipment's package

Potential for fire or burning. Do not disassemble, puncture, crush, heat or burn.

Use only with specified charger.

Keep small cells and batteries which are considered swallowable out of the reach of children.

Swallowing may lead to burns, perforation of soft tissue, and death. Severe burns can occur within 2h of ingestion.

In case of ingestion of a cell or battery, seek medical assistance promptly.



Test item particulars..... :	
Classification of installation and use..... :	To be defined in final product
Supply connection..... :	Lead wire
Recommend charging method declared by the manufacturer..... :	Charging the battery with 200mA constant current until 4.2V, then constant voltage until charge current reduces to 8mA at ambient 20°C±5°C.
Discharge current (0,2 I_c A)..... :	80mA
Specified final voltage..... :	2.75V
Upper limit charging voltage per cell..... :	4.2V
Maximum charging current..... :	400mA
Charging temperature upper limit..... :	45°C
Charging temperature lower limit..... :	0°C
Polymer cell electrolyte type..... :	<input type="checkbox"/> gel polymer <input type="checkbox"/> solid polymer <input checked="" type="checkbox"/> N/A
Possible test case verdicts:	
- test case does not apply to the test object..... :	N/A
- test object does meet the requirement..... :	P (Pass)
- test object does not meet the requirement..... :	F (Fail)
Testing..... :	
Date of receipt of test item..... :	2024-02-29
Date (s) of performance of tests..... :	2024-02-29 to 2024-03-13
General remarks:	
The test results presented in this report relate only to the object tested. This report shall not be reproduced, except in full, without the written approval of the Issuing testing laboratory. "(See Enclosure #)" refers to additional information appended to the report. "(See appended table)" refers to a table appended to the report. Throughout this report a <input type="checkbox"/> comma / <input checked="" type="checkbox"/> point is used as the decimal separator.	
Name and address of factory (ies)	Same as manufacturer

General product information:

The cell consists of the positive electrode plate, negative electrode plate, separator, electrolyte, case. The positive and negative electrode plates are housed in the case in the state being separated by the separator.

The main features of the cell are shown as below (clause 7.1.1):

Model (Cell)	Nominal capacity	Nominal voltage	Nominal Charge Current	Nominal Discharge Current	Maximum Charge Current	Maximum Discharge Current	Maximum Charge Voltage	Cut-off Voltage
582728	400mAh	3.7V	200mA	200mA	400mA	400mA	4.2V	2.75V

The main features of the cell are shown as below (clause 7.1.2):

Model (Cell)	Upper limit charge voltage	Taper-off current	Lower charge temperature	Upper charge temperature
582728	4.2V	20mA	0°C	45°C

Construction:

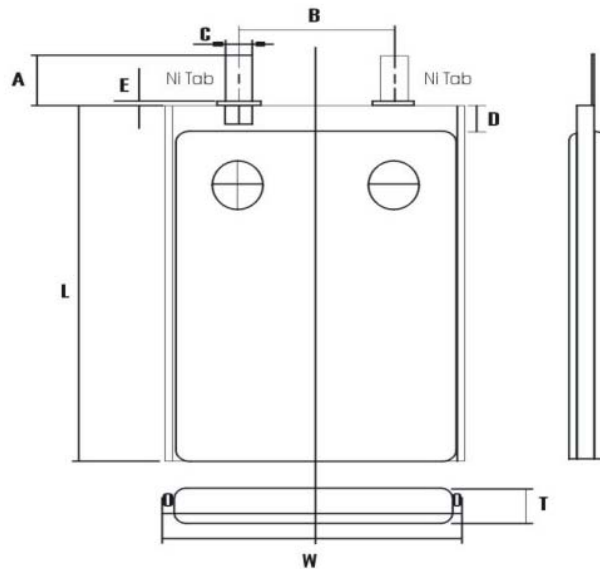

L:28.5mm Max

W:27.0mm Max

T:5.8mm Max

Cell (Unit: mm)

Circuit diagram:

None, cell only

IEC 62133-2			
Clause	Requirement + Test	Result - Remark	Verdict
4	PARAMETER MEASUREMENT TOLERANCES		P
	Parameter measurement tolerances		P
5	GENERAL SAFETY CONSIDERATIONS		P
5.1	General		P
	Cells and batteries so designed and constructed that they are safe under conditions of both intended use and reasonably foreseeable misuse		P
5.2	Insulation and wiring		N/A
	The insulation resistance between the positive terminal and externally exposed metal surfaces of the battery (excluding electrical contact surfaces) is not less than 5 MΩ	Cell only.	N/A
	Insulation resistance (MΩ)..... :		—
	Internal wiring and insulation are sufficient to withstand maximum anticipated current, voltage and temperature requirements		N/A
	Orientation of wiring maintains adequate clearances and creepage distances between conductors		N/A
	Mechanical integrity of internal connections accommodates reasonably foreseeable misuse		N/A
5.3	Venting		P
	Battery cases and cells incorporate a pressure relief mechanism or are constructed so that they relieve excessive internal pressure at a value and rate that will preclude rupture, explosion and self-ignition	Venting mechanism exists on narrow side of the pouch cell.	P
	Encapsulation used to support cells within an outer casing does not cause the battery to overheat during normal operation nor inhibit pressure relief		N/A
5.4	Temperature, voltage and current management		N/A
	Batteries are designed such that abnormal temperature rise conditions are prevented	Cell only.	N/A
	Batteries are designed to be within temperature, voltage and current limits specified by the cell manufacturer		N/A
	Batteries are provided with specifications and charging instructions for equipment manufacturers so that specified chargers are designed to maintain charging within the temperature, voltage and current limits specified		N/A
5.5	Terminal contacts		P

IEC 62133-2			
Clause	Requirement + Test	Result - Remark	Verdict
	The size and shape of the terminal contacts ensure that they can carry the maximum anticipated current		P
	External terminal contact surfaces are formed from conductive materials with good mechanical strength and corrosion resistance		P
	Terminal contacts are arranged to minimize the risk of short circuits		P
5.6	Assembly of cells into batteries		N/A
5.6.1	General		N/A
	Each battery has an independent control and protection for current, voltage, temperature and any other parameter required for safety and to maintain the cells within their operating region	Cell only.	N/A
	This protection may be provided external to the battery such as within the charger or the end devices		N/A
	If protection is external to the battery, the manufacturer of the battery provide this safety relevant information to the external device manufacturer for implementation		N/A
	If there is more than one battery housed in a single battery case, each battery has protective circuitry that can maintain the cells within their operating regions		N/A
	Manufacturers of cells specify current, voltage and temperature limits so that the battery manufacturer/designer may ensure proper design and assembly		N/A
	Batteries that are designed for the selective discharge of a portion of their series connected cells incorporate circuitry to prevent operation of cells outside the limits specified by the cell manufacturer		N/A
	Protective circuit components are added as appropriate and consideration given to the end-device application		N/A
	The manufacturer of the battery provide a safety analysis of the battery safety circuitry with a test report including a fault analysis of the protection circuit under both charging and discharging conditions confirming the compliance		N/A
5.6.2	Design recommendation		N/A
	For the battery consisting of a single cell or a single cellblock, it is recommended that the charging voltage of the cell does not exceed the upper limit of the charging voltage specified in Table 2	Cell only.	N/A

IEC 62133-2			
Clause	Requirement + Test	Result - Remark	Verdict
	For the battery consisting of series-connected plural single cells or series-connected plural cellblocks, it is recommended that the voltages of any one of the single cells or single cellblocks does not exceed the upper limit of the charging voltage, specified in Table 2, by monitoring the voltage of every single cell or the single cellblocks		N/A
	For the battery consisting of series-connected plural single cells or series-connected plural cellblocks, it is recommended that charging is stopped when the upper limit of the charging voltage is exceeded for any one of the single cells or single cellblocks by measuring the voltage of every single cell or the single cellblocks		N/A
	For batteries consisting of series-connected cells or cell blocks, nominal charge voltage are not counted as an overcharge protection		N/A
	For batteries consisting of series-connected cells or cell blocks, cells have closely matched capacities, be of the same design, be of the same chemistry and be from the same manufacturer		N/A
	It is recommended that the cells and cell blocks are not discharged beyond the cell manufacturer's specified final voltage		N/A
	For batteries consisting of series-connected cells or cell blocks, cell balancing circuitry are incorporated into the battery management system		N/A
5.6.3	Mechanical protection for cells and components of batteries	Cell only.	N/A
	Mechanical protection for cells, cell connections and control circuits within the battery are provided to prevent damage as a result of intended use and reasonably foreseeable misuse		N/A
	The mechanical protection can be provided by the battery case or it can be provided by the end product enclosure for those batteries intended for building into an end product		N/A
	The battery case and compartments housing cells are designed to accommodate cell dimensional tolerances during charging and discharging as recommended by the cell manufacturer		N/A
	For batteries intended for building into a portable end product, testing with the battery installed within the end product is considered when conducting mechanical tests		N/A
5.7	Quality plan		P

IEC 62133-2			
Clause	Requirement + Test	Result - Remark	Verdict
	The manufacturer prepares and implements a quality plan that defines procedures for the inspection of materials, components, cells and batteries and which covers the whole process of producing each type of cell or battery	Complied. Quality plan provided.	P
5.8	Battery safety components	See TABLE: Critical components information	N/A

6	TYPE TEST AND SAMPLE SIZE		P
	Tests are made with the number of cells or batteries specified in Table 1 using cells or batteries that are not more than six months old		P
	The internal resistance of coin cells are measured in accordance with Annex D. Coin cells with internal resistance less than or equal to 3 Ω are tested in accordance with Table 1	Not coin cells	N/A
	Unless otherwise specified, tests are carried out in an ambient temperature of 20 °C ± 5 °C		P
	The safety analysis of 5.6.1 identify those components of the protection circuit that are critical for short-circuit, overcharge and over discharge protection	Cell only.	N/A
	When conducting the short-circuit test, consideration is given to the simulation of any single fault condition that is likely to occur in the protecting circuit that would affect the short-circuit test	Cell only.	N/A

7	SPECIFIC REQUIREMENTS AND TESTS		P
7.1	Charging procedure for test purposes		P
7.1.1	First procedure		P
	This charging procedure applies to subclauses other than those specified in 7.1.2		P
	Unless otherwise stated in this document, the charging procedure for test purposes is carried out in an ambient temperature of 20 °C ± 5 °C, using the method declared by the manufacturer	See page 4.	P
	Prior to charging, the battery has been discharged at 20 °C ± 5 °C at a constant current of 0,2 It A down to a specified final voltage	See page 4.	P
7.1.2	Second procedure		P
	This charging procedure applies only to 7.3.1, 7.3.4, 7.3.5, and 7.3.9		P

IEC 62133-2			
Clause	Requirement + Test	Result - Remark	Verdict
	After stabilization for 1 h to 4 h, at an ambient temperature of the highest test temperature and the lowest test temperature, respectively, as specified in Table 2, cells are charged by using the upper limit charging voltage and maximum charging current, until the charging current is reduced to 0,05 It A, using a constant current to constant voltage charging method	Charge temperature range: 0-45°C declared. 0°C used for lower limit tests. 45°C used for upper limit tests.	P
7.2	Intended use		P
7.2.1	Continuous charging at constant voltage (cells)		P
	Fully charged cells are subjected for 7 days to a charge using the charging method for current and standard voltage specified by the cell manufacturer	Charging for 7 days with 200mA.	P
	Results: no fire, no explosion, no leakage..... :	(See appended table 7.2.1)	P
7.2.2	Case stress at high ambient temperature (battery)	Cell only.	N/A
	Oven temperature (°C)..... :		—
	Results: no physical distortion of the battery case resulting in exposure of internal protective components and cells		N/A
7.3	Reasonably foreseeable misuse		P
7.3.1	External short-circuit (cell)	Tested complied.	P
	The cells were tested until one of the following occurred:		P
	- 24 hours elapsed; or		N/A
	- The case temperature declined by 20 % of the maximum temperature rise		P
	Results: no fire, no explosion..... :	(See appended table 7.3.1)	P
7.3.2	External short-circuit (battery)	Cell only.	N/A
	The batteries were tested until one of the following occurred:		N/A
	- 24 hours elapsed; or		N/A
	- The case temperature declined by 20 % of the maximum temperature rise		N/A
	In case of rapid decline in short circuit current, the battery pack remained on test for an additional one hour after the current reached a low end steady state condition		N/A
	A single fault in the discharge protection circuit is conducted on one to four (depending upon the protection circuit) of the five samples before conducting the short-circuit test		N/A

IEC 62133-2			
Clause	Requirement + Test	Result - Remark	Verdict
	A single fault applies to protective component parts such as MOSFET (metal oxide semiconductor field-effect transistor), fuse, thermostat or positive temperature coefficient (PTC) thermistor		N/A
	Results: no fire, no explosion.....:		N/A
7.3.3	Free fall	Tested complied.	P
	Results: no fire, no explosion	No fire. No explosion	P
7.3.4	Thermal abuse (cells)	Tested complied.	P
	Oven temperature (°C).....:	130°C	—
	Results: no fire, no explosion	No fire. No explosion	P
7.3.5	Crush (cells)	Tested complied.	P
	The crushing force was released upon:		P
	- The maximum force of 13 kN ± 0,78 kN has been applied; or		P
	- An abrupt voltage drop of one-third of the original voltage has been obtained		N/A
	Results: no fire, no explosion.....:	(See appended table 7.3.5)	P
7.3.6	Over-charging of battery	Cell only.	N/A
	The supply voltage which is:		N/A
	- 1,4 times the upper limit charging voltage presented in Table A.1 (but not to exceed 6,0 V) for single cell/cell block batteries or		N/A
	- 1,2 times the upper limit charging voltage resented in Table A.1 per cell for series connected multi-cell batteries, and		N/A
	- Sufficient to maintain a current of 2,0 It A throughout the duration of the test or until the supply voltage is reached		N/A
	Test was continued until the temperature of the outer casing:		N/A
	- Reached steady state conditions (less than 10 °C change in 30-minute period); or		N/A
	- Returned to ambient		N/A
	Results: no fire, no explosion.....:		N/A
7.3.7	Forced discharge (cells)	Tested complied.	P
	Discharge a single cell to the lower limit discharge voltage specified by the cell manufacturer		P

IEC 62133-2			
Clause	Requirement + Test	Result - Remark	Verdict
	The discharged cell is then subjected to a forced discharge at 1 It A to the negative value of the upper limit charging voltage		P
	- The discharge voltage reaches the negative value of upper limit charging voltage within the testing duration. The voltage is maintained at the negative value of the upper limit charging voltage by reducing the current for the remainder of the testing duration		N/A
	- The discharge voltage does not reach the negative value of upper limit charging voltage within the testing duration. The test is terminated at the end of the testing duration		P
	Results: no fire, no explosion.....	(See appended table 7.3.7)	P
7.3.8	Mechanical tests (batteries)		N/A
7.3.8.1	Vibration	Cell only.	N/A
	Results: no fire, no explosion, no rupture, no leakage or venting.....		N/A
7.3.8.2	Mechanical shock	Cell only.	N/A
	Results: no leakage, no venting, no rupture, no explosion and no fire.....		N/A
7.3.9	Design evaluation – Forced internal short-circuit (cells)	Tested complied.	P
	The cells complied with national requirement for.....	France, Japan, Republic of Korea, Switzerland	—
	The pressing was stopped upon:		P
	- A voltage drop of 50 mV has been detected; or		N/A
	- The pressing force of 800 N (cylindrical cells) or 400 N (prismatic cells) has been reached	400N for prismatic cells.	P
	Results: no fire.....	(See appended table 7.3.9)	P
8	INFORMATION FOR SAFETY		P
8.1	General		P
	Manufacturers of secondary cells provides information about current, voltage and temperature limits of their products	Information for safety mentioned in manufacturer's specifications.	P
	Manufacturers of batteries provides information regarding how to minimize and mitigate hazards to equipment manufacturers or end-users		N/A

IEC 62133-2			
Clause	Requirement + Test	Result - Remark	Verdict
	Systems analyses are performed by device manufacturers to ensure that a particular battery design prevents hazards from occurring during use of a product		N/A
	As appropriate, any information relating to hazard avoidance resulting from a system analysis is provided to the end user		N/A
	Do not allow children to replace batteries without adult supervision		P
8.2	Small cell and battery safety information	Small cells.	P
	The following warning language is to be provided with the information packaged with the small cells and batteries or equipment using them:	Information for safety mentioned on equipment's package.	P
	- Keep small cells and batteries which are considered swallowable out of the reach of children		P
	- Swallowing may lead to burns, perforation of soft tissue, and death. Severe burns can occur within 2 h of ingestion		P
	- In case of ingestion of a cell or battery, seek medical assistance promptly		P
9	MARKING		P
9.1	Cell marking		P
	Cells are marked as specified in IEC 61960, except coin cells	The cell is marked in accordance with IEC61960, also see page 4.	P
	Coin cells whose external surface area is too small to accommodate the markings on the cells show the designation and polarity	Not coin cells.	N/A
	By agreement between the cell manufacturer and the battery and/or end product manufacturer, component cells used in the manufacture of a battery need not be marked		N/A
9.2	Battery marking	Cell only.	N/A
	Batteries are marked as specified in IEC 61960, except for coin batteries		N/A
	Coin batteries whose external surface area is too small to accommodate the markings on the batteries show the designation and polarity		N/A
	Batteries are marked with an appropriate caution statement		N/A

IEC 62133-2			
Clause	Requirement + Test	Result - Remark	Verdict
	- Terminals have clear polarity marking on the external surface of the battery, or	The "Red wire: +" and "Black wire: -" polarity explicitly marked on surface of the battery.	P
	- Not be marked with polarity markings if the design of the external connector prevents reverse polarity connections		N/A
9.3	Caution for ingestion of small cells and batteries		N/A
	Coin cells and batteries identified as small batteries include a caution statement regarding the hazards of ingestion in accordance with 8.2	Not coin cells	N/A
	Small cells and batteries are intended for direct sale in consumer-replaceable applications, caution for ingestion is given on the immediate package	Not intended for direct sale.	N/A
9.4	Other information		N/A
	The following information are marked on or supplied with the battery:		N/A
	- Storage and disposal instructions		N/A
	- Recommended charging instructions		N/A
10	PACKAGING AND TRANSPORT		P
	Packaging for coin cells are not be small enough to fit within the limits of the ingestion gauge of Figure 3		N/A
ANNEX A	CHARGING AND DISCHARGING RANGE OF SECONDARY LITHIUM ION CELLS FOR SAFE USE		P
A.1	General		P
A.2	Safety of lithium ion secondary battery	Complied.	P
A.3	Consideration on charging voltage	Complied.	P
A.3.1	General		P
A.3.2	Upper limit charging voltage	4.2V applied.	P
A.3.2.1	General		P
A.3.2.2	Explanation of safety viewpoint		P
A.3.2.3	Safety requirements, when different upper limit charging voltage is applied	4.2V applied.	N/A
A.4	Consideration of temperature and charging current		P
A.4.1	General		P

IEC 62133-2			
Clause	Requirement + Test	Result - Remark	Verdict
A.4.2	Recommended temperature range	Charging temperature range declared by client is: 0-45°C	P
A.4.2.1	General		P
A.4.2.2	Safety consideration when a different recommended temperature range is applied		N/A
A.4.3	High temperature range		N/A
A.4.3.1	General		N/A
A.4.3.2	Explanation of safety viewpoint		N/A
A.4.3.3	Safety considerations when specifying charging conditions in the high temperature range		N/A
A.4.3.4	Safety considerations when specifying a new upper limit in the high temperature range		N/A
A.4.4	Low temperature range		N/A
A.4.4.1	General		N/A
A.4.4.2	Explanation of safety viewpoint		N/A
A.4.4.3	Safety considerations, when specifying charging conditions in the low temperature range		N/A
A.4.4.4	Safety considerations when specifying a new lower limit in the low temperature range		N/A
A.4.5	Scope of the application of charging current		P
A.4.6	Consideration of discharge		P
A.4.6.1	General		P
A.4.6.2	Final discharge voltage and explanation of safety viewpoint	Cell specified final voltage 2.75V, not exceed 2.75V specified by cell manufacturer.	P
A.4.6.3	Discharge current and temperature range		P
A.4.6.4	Scope of application of the discharging current		P
A.5	Sample preparation		P
A.5.1	General		P
A.5.2	Insertion procedure for nickel particle to generate internal short		P
A.5.3	Disassembly of charged cell		P
A.5.4	Shape of nickel particle		P
A.5.5	Insertion of nickel particle in cylindrical cell		N/A
A.5.5.1	Insertion of nickel particle in winding core		N/A
A.5.5.2	Marking the position of the nickel particle on both ends of the winding core of the separator		N/A

IEC 62133-2			
Clause	Requirement + Test	Result - Remark	Verdict
A.5.6	Insertion of nickel particle in prismatic cell		P
A.6	Experimental procedure of the forced internal short-circuit test		P
A.6.1	Material and tools for preparation of nickel particle		P
A.6.2	Example of a nickel particle preparation procedure		P
A.6.3	Positioning (or placement) of a nickel particle		P
A.6.4	Damaged separator precaution		P
A.6.5	Caution for rewinding separator and electrode		P
A.6.6	Insulation film for preventing short-circuit		P
A.6.7	Caution when disassembling a cell		P
A.6.8	Protective equipment for safety		P
A.6.9	Caution in the case of fire during disassembling		P
A.6.10	Caution for the disassembling process and pressing the electrode core		P
A.6.11	Recommended specifications for the pressing device		P
ANNEX B	RECOMMENDATIONS TO EQUIPMENT MANUFACTURERS AND BATTERY ASSEMBLERS		N/A
ANNEX C	RECOMMENDATIONS TO THE END-USERS		N/A
ANNEX D	MEASUREMENT OF THE INTERNAL AC RESISTANCE FOR COIN CELLS		N/A
D.1	General	Not coin cells.	N/A
D.2	Method		N/A
	A sample size of three coin cells is required for this measurement		N/A
	Coin cells with an internal resistance greater than 3 Ω require no further testing..... :	(See appended table D.2)	N/A
	Coin cells with an internal resistance less than or equal to 3 Ω are subjected to the testing according to Clause 6 and Table 1		N/A
ANNEX E	PACKAGING AND TRANSPORT		P
ANNEX F	COMPONENT STANDARDS REFERENCES		N/A

5.1 – 5.6					
TABLE: Critical components information					
Object/part no.	Manufacturer/ trademark	Type/model	Technical data	Standard	Mark(s) of conformity
Lead wire	DONGGUAN HUMEN TOP RICH WIRE & CABLE FACTORY	1571	80°C, 28AWG, 30Vac	UL 758	UL E315320
Lead wire (Alternative)	Interchangeable	Interchangeable	80°C, 28AWG, 30Vac	UL 758	UL approved
-Positive electrode	--	--	LiCoO ₂ , PVDF, NMP, Conductive Additive	--	--
-Negative electrode	--	--	Graphite, CMC, SBR, Distilled Water, Conductive	--	--
-Separator	--	--	Shutdown temperature: 130°C	--	--
-Electrolyte	--	--	LiPF ₆ +EMC+EC+DMC	--	--
Supplementary information: N/A					

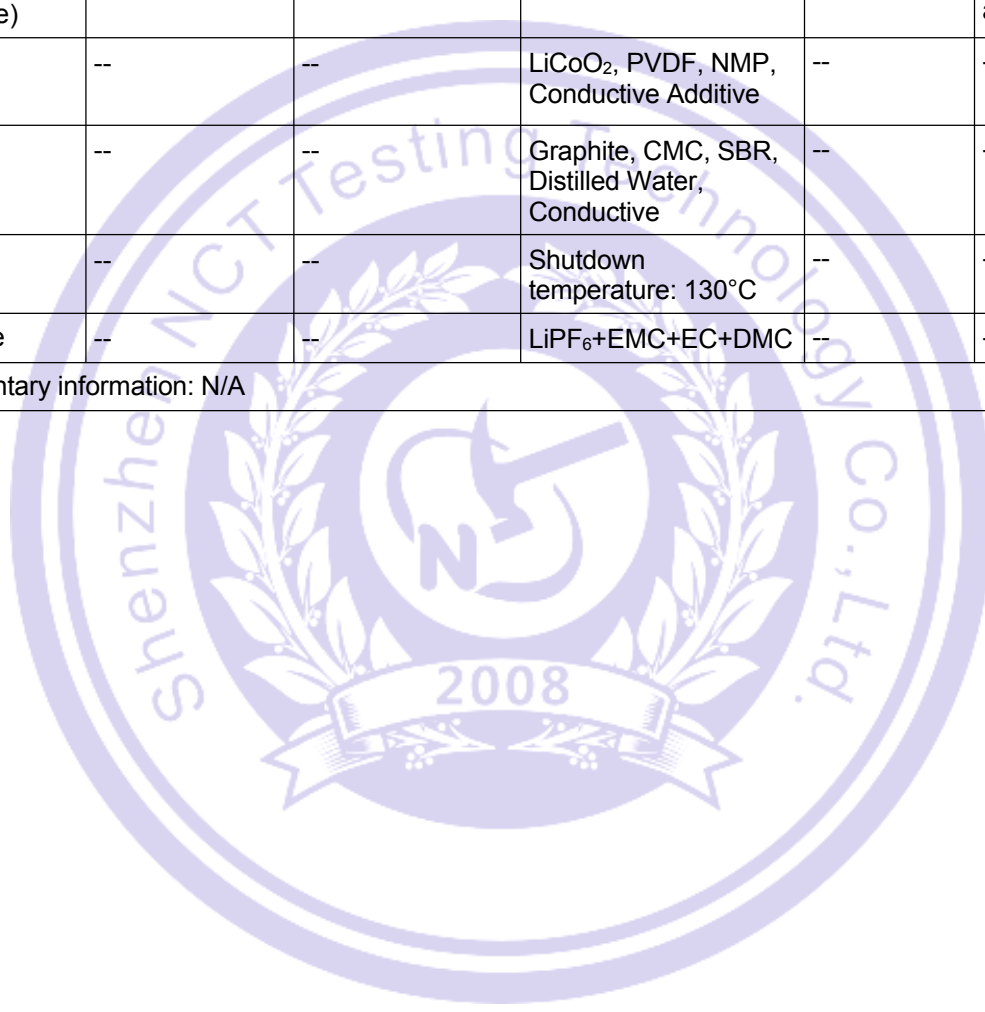

7.2.1	TABLE: Continuous charging at constant voltage (cells)				P
Sample no.	Recommended charging voltage Vc (Vdc)	Recommended charging current I _{rec} (A)	OCV before test(Vdc)	Results	
Cell #1	4.20	0.20	4.18	P	
Cell #2	4.20	0.20	4.18	P	
Cell #3	4.20	0.20	4.17	P	
Cell #4	4.20	0.20	4.17	P	
Cell #5	4.20	0.20	4.18	P	
Supplementary information: - No fire or explosion - No leakage					

7.3.1	TABLE: External short-circuit (cell)					P
Sample no.	Ambient T (°C)	OCV before test (Vdc)	Resistance of circuit (mΩ)	Maximum case temperature rise ΔT (°C)	Results	
Samples charged at charging temperature upper limit (45°C)						
Cell #1	55.6	4.16	92.5	112.9	P	
Cell #2	55.6	4.17	89.6	114.5	P	
Cell #3	55.6	4.16	90.2	111.3	P	
Cell #4	55.6	4.16	88.8	113.7	P	
Cell #5	55.6	4.17	91.3	110.2	P	
Samples charged at charging temperature lower limit (0°C)						
Cell #6	55.5	4.13	93.4	118.3	P	
Cell #7	55.5	4.13	89.5	119.5	P	
Cell #8	55.5	4.14	87.6	116.4	P	
Cell #9	55.5	4.13	91.2	117.8	P	
Cell #10	55.5	4.14	90.8	117.9	P	
Supplementary information: - No fire or explosion						

7.3.2	TABLE: External short-circuit (battery)					N/A
Sample no.	Ambient T (°C)	OCV before test (Vdc)	Resistance of circuit (mΩ)	Maximum case temperature rise ΔT (°C)	Component single fault condition	Results
Supplementary information: - No fire or explosion						

7.3.5	TABLE: Crush (cells)				P
Sample no.	OCV before test (Vdc)	OCV at removal of crushing force (Vdc)	Maximum force applied to the cell during crush (kN)	Results	
Samples charged at charging temperature upper limit (45°C)					
Cell #1	4.16	4.15	13.02	P	
Cell #2	4.16	4.16	12.97	P	
Cell #3	4.17	4.16	12.99	P	
Cell #4	4.16	4.15	13.03	P	
Cell #5	4.17	4.16	13.01	P	
Samples charged at charging temperature lower limit (0°C)					
Cell #6	4.14	4.13	13.03	P	
Cell #7	4.14	4.13	12.97	P	
Cell #8	4.13	4.12	12.99	P	
Cell #9	4.13	4.13	13.01	P	
Cell #10	4.14	4.14	13.00	P	
Supplementary information: - No fire or explosion					

7.3.6	TABLE: Over-charging of battery				N/A
Constant charging current (A).....:					—
Supply voltage (Vdc).....:					—
Sample no.	OCV before charging (Vdc)	Total charging time (minute)	Maximum outer case temperature (°C)	Results	
Supplementary information: - No fire or explosion					

7.3.7	TABLE: Forced discharge (cells)				P
Sample no.	OCV before application of reverse charge (Vdc)	Measured reverse charge I_r (A)	Lower limit discharge voltage (Vdc)	Results	
Cell #1	3.05	0.40	2.75	P	
Cell #2	3.04	0.40	2.75	P	
Cell #3	3.04	0.40	2.75	P	
Cell #4	3.05	0.40	2.75	P	
Cell #5	3.04	0.40	2.75	P	
Supplementary information: - No fire or explosion					

7.3.8.1	TABLE: Vibration					N/A
Sample no.	OCV before test (Vdc)	OCV after test (Vdc)	Mass before test (g)	Mass after test(g)	Results	
Supplementary information: - No fire or explosion - No rupture - No leakage - No venting						

7.3.8.2	TABLE: Mechanical shock					N/A
Sample no.	OCV before test (Vdc)	OCV after test (Vdc)	Mass before test (g)	Mass after test(g)	Results	

Supplementary information:

- No fire or explosion
- No rupture
- No leakage
- No venting

7.3.9	TABLE: Forced internal short circuit (cells)					P
Sample no.	Chamber ambient T (°C)	OCV before test (Vdc)	Particle location ¹⁾	Maximum applied pressure (N)	Results	
Samples charged at charging temperature upper limit (45°C)						
Cell #1	45	4.16	1	400	P	
Cell #2	45	4.16	1	400	P	
Cell #3	45	4.17	1	400	P	
Cell #4	45	4.16	1	400	P	
Cell #5	45	4.17	1	400	P	
Samples charged at charging temperature lower limit (0°C)						
Cell #6	0	4.14	1	400	P	
Cell #7	0	4.13	1	400	P	
Cell #8	0	4.14	1	400	P	
Cell #9	0	4.14	1	400	P	
Cell #10	0	4.13	1	400	P	

Supplementary information:

¹⁾Identify one of the following:

- 1: Nickel particle inserted between positive and negative (active material) coated area.
- 2: Nickel particle inserted between positive aluminium foil and negative active material coated area.

- No fire or explosion

D.2	TABLE: Internal AC resistance for coin cells			N/A
Sample no.	Ambient T (°C)	Store time (h)	Resistance Rac (Ω)	Results ¹⁾

Supplementary information:
¹⁾ Coin cells with internal resistance less than or equal to 3 Ω, see test result on corresponding tables



Appendix 1: Photo Documentation

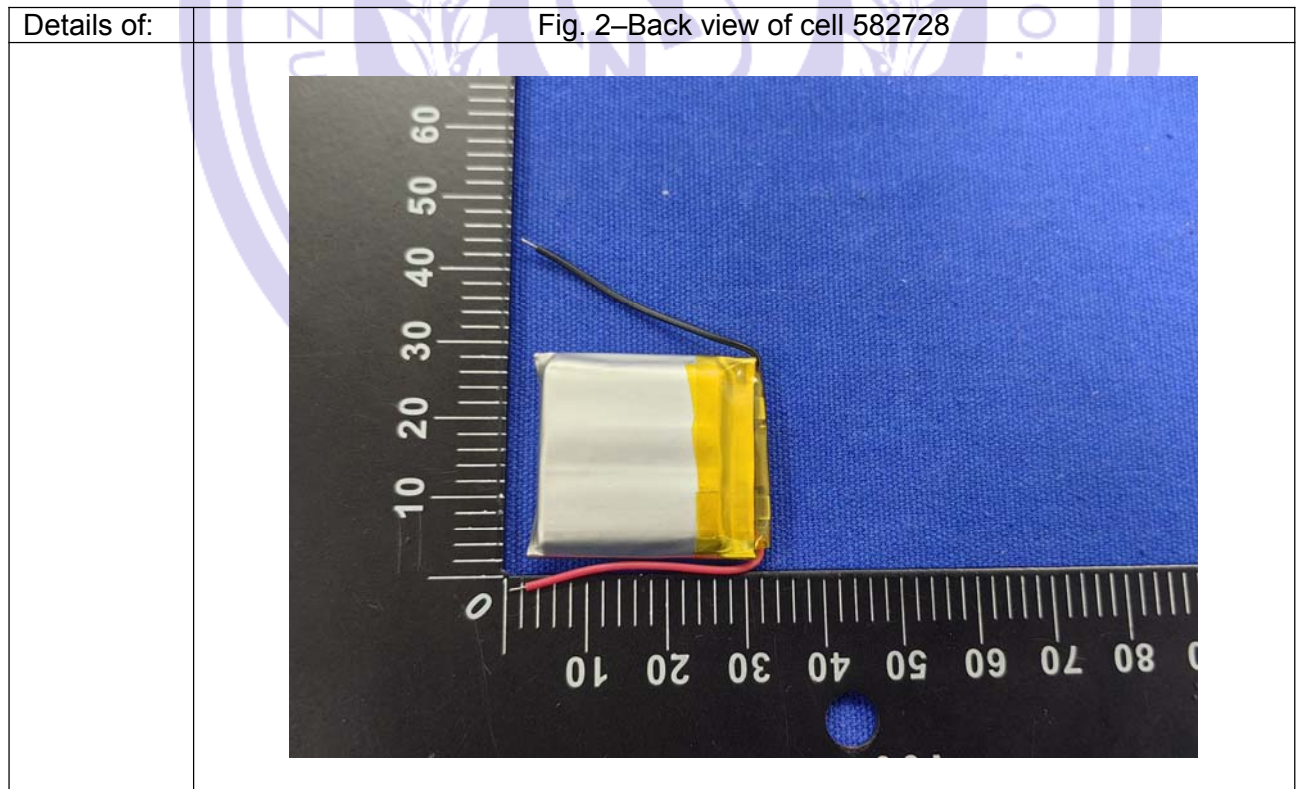
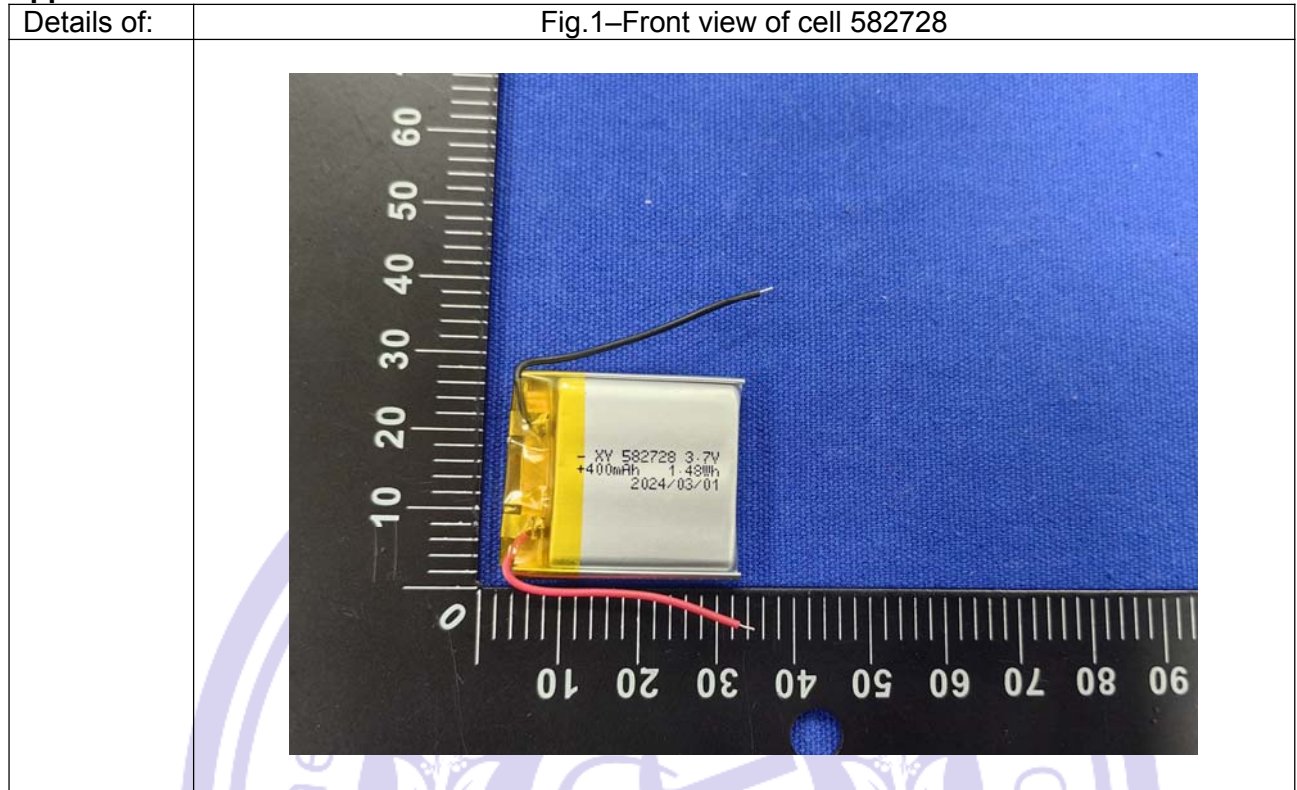

---End of Test Report---